

## TECHNICAL DATA SHEET

# BauderSOLAR F XL flat roof photovoltaic mounting system for larger format modules

BauderSOLAR F XL is a flat roof PV mounting solution for framed solar modules. The mounting units are secured to the roof using a unique membrane-to-membrane welding technique. This installation method means that the roof is not compromised by penetrations for fixings, nor does it require additional ballast, which would add additional weight loading to the roof.

### Intended Use

BauderSOLAR F XL is specifically designed to be installed on specific Bauder bituminous or single ply waterproofing systems and provide a lightweight, low risk and quick to install mounting solution for larger format framed solar modules manufactured by our module partners.

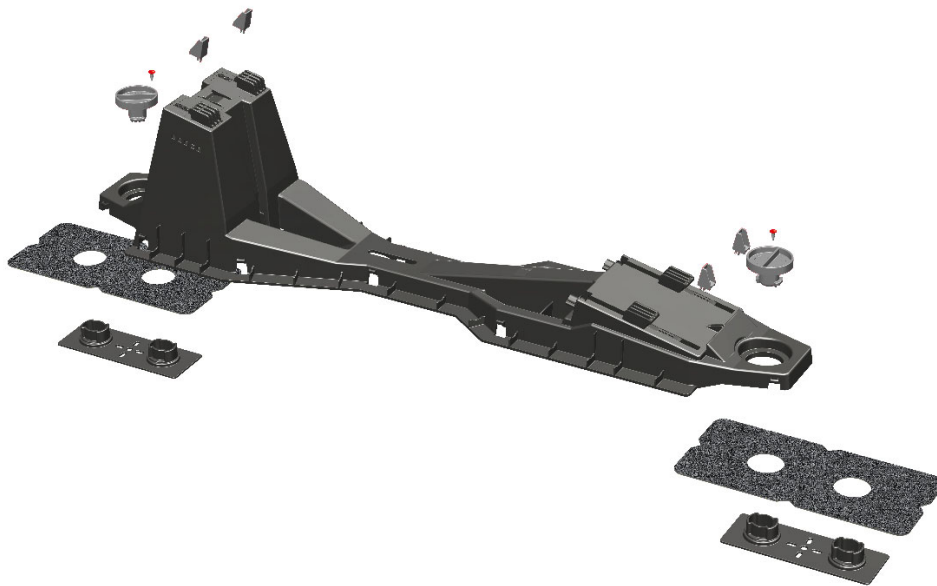







### UNITED KINGDOM

Bauder Ltd  
70 Landseer Road, Ipswich, Suffolk IP3 0DH  
T: +44 (0)1473 257671 E: [technical@bauder.co.uk](mailto:technical@bauder.co.uk)  
[bauder.co.uk](http://bauder.co.uk)

### IRELAND

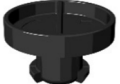
Bauder Ltd  
O'Duffy Centre, Carrickmacross, Co. Monaghan  
T: +353 (0)42 9692 333 E: [technical@bauder.ie](mailto:technical@bauder.ie)  
[bauder.ie](http://bauder.ie)

TECHNICAL DATA SHEET

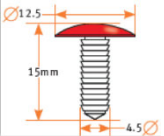
No.	Sketch	Name	Quantity	Description	Recycling
1		<b>BauderSOLAR F XL</b> main substructure	1 Pcs	<b>Substructure</b> with integrated module <b>clamps</b> (Polypropylene PP) Weight = 4.8kg/unit 1550mm x 340mm x 310mm	
2		<b>BauderSOLAR MST-BIT</b> welding sleeve	Subject to design	<b>Welding sleeve</b> for welding to Bauder bitumen roof membranes 440mm x 360mm x 5.2mm	EWC number 170302 (bitumen)
2		<b>BauderSOLAR MST-PVC</b> welding sleeve	Subject to design	<b>Welding sleeve</b> for welding to Bauder Thermofol PVC roof membranes 440mm x 360mm x 1.8mm	EWC number 170203 (PVC)
2		<b>BauderSOLAR MST-FPO</b> welding sleeve	Subject to design	<b>Welding sleeve</b> for welding to Bauder Thermoplan FPO roof membranes 440mm x 360mm x 1.8mm	EWC number 170203 (FPO)
3		<b>BauderSOLAR GF</b> Baseplate	Subject to design	<b>Receivers</b> for the bayonet twist lock fitting (Polyamide PA6-GF30) 280mm x 100mm x 35mm	
4		<b>BauderSOLAR BJT</b> bayonet Cap	2 Pcs	<b>Twist lock</b> for locking to the base plate (Polyamide PA6-GF30) 80mm x 35mm	
5		<b>BauderSOLAR MDS</b> locking Pin	4 Pcs	<b>Module securing device</b> with two snap-in hooks below (Polypropylene PP)	
6		<b>BauderSOLAR BSP</b> Bayonet Safety Pin	2 Pcs	<b>Push fit pin</b> to lock Bayonet Cap in place (Nylon)	

**UNITED KINGDOM**

Bauder Ltd  
70 Landseer Road, Ipswich, Suffolk IP3 0DH  
T: +44 (0)1473 257671 E: [technical@bauder.co.uk](mailto:technical@bauder.co.uk)  
[bauder.co.uk](http://bauder.co.uk)

**IRELAND**

Bauder Ltd  
O'Duffy Centre, Carrickmacross, Co. Monaghan  
T: +353 (0)42 9692 333 E: [technical@bauder.ie](mailto:technical@bauder.ie)  
[bauder.ie](http://bauder.ie)

## TECHNICAL DATA SHEET

### CERTIFICATION AND ENVIRONMENTAL INFORMATION

International Standards Organisation (ISO)	<p>ISO 9001:2015 Quality Management Certificates EN1271 (UK) and 70499/03-15_e (Germany).</p> <p>ISO 14001:2015 Environmental Management Certificates A10552 (UK) and 70499/03-15_d (Germany).</p> <p>ISO 50001: 2011 Energy Management Certificate 70499/03-15_c (Germany)</p>
--	---

### INSTALLATION GUIDANCE

BauderSOLAR F XL is designed to be installed by a Bauder approved and trained contractor only. Please see BauderSOLAR installation guidelines for a full breakdown of the system installation methodology.

The number of mounts and fixings required will vary from project to project. System weight can also vary depending on module choice and system design. Please contact Bauder for a project specific technical report for further information. System weight, windload and snowload calculations will also be provided on a project specific basis.

BauderSOLAR F XL can be installed on slopes of up to 5° for bituminous membranes and 10° for single-ply membranes.

BauderSOLAR F XL is intended to be used in combination with the following membranes:

- Bauder Total Roof System
- Bauderflex
- Bauder Thermofol – minimum 1.8mm mechanically fixed or adhered, all colours\*
- Bauder Thermofol Fleece Back – minimum 1.5mm mechanically fixed or adhered, all colours\*
- Bauder Thermoplan – minimum 1.5mm mechanically fixed, all colours

BauderSOLAR F XL is compatible with modules that meet the following criteria:

Module Length = ca. 2000mm maximum  
 Internal frame (B-B) = 979mm-1080mm  
 Module depth (E-E) = minimum 25mm  
 Module flange width (C-C) = Minimum 10mm

Specific test standards and results are stated in Bauder product datasheets and our specification service should be used to confirm suitability to individual project.

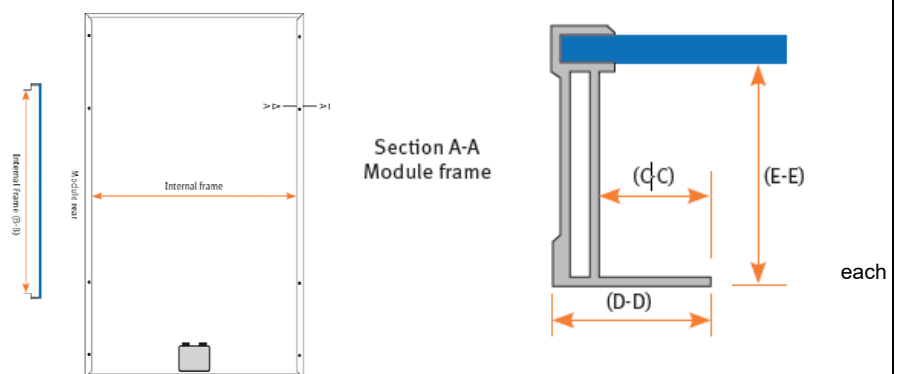

### STORAGE GUIDANCE

The product should be stored dry, protected against weathering, and must not be exposed to temperatures exceeding 35°C. The products must not be exposed to a direct naked flame or other ignition sources, or to solvents or other chemicals.

Ensure the product(s) are clear of buildings and any other storage areas. Where there are storage containers on site, these may be suitable for storing products.

Bauder reserves the right to update this data set without prior notice and this document is uncontrolled if printed or stored. Always confirm the latest version is used for the adoption of this product, available from our website: [bauder.co.uk/technical-centre](http://bauder.co.uk/technical-centre).

Intended use of this product should be verified with Bauder to ensure suitability and compliance with applicable guidance, regulations, legislations, project requirements, specifications, and installation techniques.

#### UNITED KINGDOM

Bauder Ltd  
 70 Landseer Road, Ipswich, Suffolk IP3 0DH  
 T: +44 (0)1473 257671 E: [technical@bauder.co.uk](mailto:technical@bauder.co.uk)  
[bauder.co.uk](http://bauder.co.uk)

#### IRELAND

Bauder Ltd  
 O'Duffy Centre, Carrickmacross, Co. Monaghan  
 T: +353 (0)42 9692 333 E: [technical@bauder.ie](mailto:technical@bauder.ie)  
[bauder.ie](http://bauder.ie)