

Bauder Bitumen Vertical Refurb Outlet DN95 with s/s leaf guard & mechanical seal

12.02.2026

Product description

A stainless-steel rainwater outlet with vertical spigot. Factory bonded membrane flange attached to the outlet allows for ease of installation. Also supplied with a stainless steel leafguard and mechanical seal. Outlet has a flow rate of 4.08 litres/sec based upon requirements of BS EN 12056:3:2000.

Application fields

For use with Bauder bituminous waterproofing membranes when connecting into conventional gravity drainage systems. The product is designed to be used in refurbishment roof scenarios. The spigot when fitted into an existing outlet using the mechanical seal, will accommodate internal diameters ranging from 95 to 110mm.



Article Number

Bitumen Vertical Refurb Outlet DN95 **GB14120280**
Mechanical seal tightening tool **GB14120300**

Website link

<https://www.bauder.co.uk/products/bitumen-vertical-refurbishment-outlets>

| Characteristic - outlet | Unit | Value |
|-----------------------------------|------------|---------|
| Length of outlet including spigot | mm | 400 |
| Diameter of spigot (external) | mm | 95 |
| Width of bituminous flange | mm | 500 |
| Length of bituminous flange | mm | 500 |
| Thickness of bituminous flange | mm | 2.7 |
| Flange surface finish (bottom) | - | bitumen |
| Flange surface finish (top) | - | mica |
| Outlet and flange combined weight | kg | 1.84 |
| Flow rate performance | litres/sec | 4.08* |

*Flow rate performance data using a 35mm head of water (including leaf guard), based upon requirements of BS EN 12056:3:2000. Further flow rate performance data can be obtained within this document. For bespoke drainage calculation performance data, please contact Bauder Limited.

| Characteristic – leaf guard | Unit | Value |
|-----------------------------|------|-----------|
| Width | mm | 210 |
| Length | mm | 210 |
| Height | mm | 43 |
| To suit outlet diameter | mm | 50 to 160 |
| Weight | kg | 0.28 |
| Tightening nut | mm | 10 |

| Characteristic – mechanical seal | Unit | Value |
|----------------------------------|------|-----------------------------------|
| Width | mm | 95 |
| Shape | - | Circular |
| Length | mm | 105 total length. 50 into outlet. |
| To suit existing pipe diameter | mm | 95 to 110 |
| Weight | kg | 0.35 |

Storage guidance

The product should be stored dry, protected against weathering, and must not be exposed to temperatures exceeding 35°C. The products must not be exposed to a direct naked flame or other ignition sources, or to solvents or other chemicals. Ensure the product(s) are clear of buildings and any other storage areas. Where there are storage containers on site, these may be suitable for storing products. Outlet bituminous flanges that have become wet must be allowed to fully dry out naturally before use. The leaf guard and mechanical seal will be supplied with the outlet itself.

Packaging material

The outlet will be delivered in a cardboard box (readily recyclable). Also, within the cardboard box will be the leaf guard and seal which will come packaged within a low-density polyethylene bag (readily recyclable), which weighs 29 grams.

Handling/PPE

All persons using the product should be fully aware of the manual handling methods as roofing materials are heavy and can cause serious injury. When using the product, installers should be provided with, and wear, suitable personal protective equipment.

Technical data sheet

Disposal guidance

Disposing of any waste material must be carried out in accordance with national regulations.

Further information/ documents

Current documents such as brochures, installation guides, etc. can be found by visiting www.bauder.co.uk

International Standards Organisation (ISO)

ISO 9001:2015 Quality Management
Certificates EN1271 (UK)

ISO 14001:2015 Environmental Management Certificates
A10552 (UK)

Dimensions:

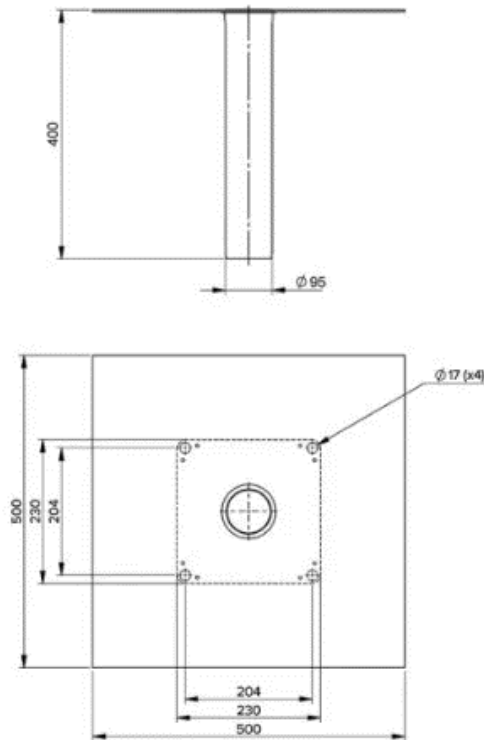

Leafguard and mechanical seal:

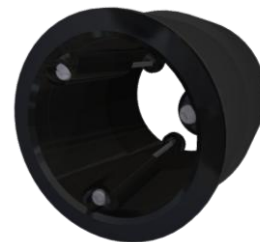

Mechanical seal tightening tool:



Installation Guidance and data: Please refer to the Bauder Installation Guide and project specification for guidance.

Technical data sheet

Fixing:

The existing pipe bore should be first cleaned to ensure a good seal.

The outlet is to be secured through to the structural deck by a minimum of four fasteners through the fixing points in the steel plate to obtain an adequate attachment to the deck substrate material.



When fixing through existing outlets, the long outlet spigot should extend beyond the spigot of the existing unit to form a seal with the downpipe beyond and should then be cut to the length required.

Insert the thin part of the mechanical seal into the outlet stem:



Tighten the stainless-steel screws using the mechanical seal tightening tool until the top half of the seal has expanded.



The entire component is then placed into the roof drain pipe.

The stainless-steel screws are then further tightened until hand tight which will expand the bottom half of the seal against the drainpipe to ensure a robust seal between the outlet and pipe is achieved.

We would recommend using a suitable silicone lubricant between the seal and pipe to ensure the seal or pipe is not damaged in the process.

Once the outlet has been installed, the leaf guard can be inserted into the outlet opening and tightened with a 10mm spanner/socket, being careful not to overtighten.

Connectivity to below deck drainage pipework to be the responsibility of the plumbing contractor/drainage engineer.

Technical data sheet

Drainage performance of the outlet:

The figures below are based upon the requirements of BS EN 12056: 3: 2000 and performances are given within 1/3 rainwater pipe capacity limits as required by BS EN 12056.

Flow rates are typically taken using a 35 mm head of water (including leaf guard and mechanical seal), which for the Bitumen Vertical Refurb Outlet DN95 gives a flow rate performance of 4.08 litres/sec.

| Head of water (mm) | | | | | | | |
|--------------------|-----|------|------|------|------|------|------|
| Size | 7.9 | 15.8 | 27.7 | 35 | 42.4 | 65.5 | 82.9 |
| 95 | 0.5 | 1.4 | 2.7 | 4.08 | 5.6 | 7.9 | 8.6 |

When designing a rainwater scheme, the following considerations should apply:

Always make provision for an additional back-up outlet to ensure that the roof will continue to drain in the event of a blockage, even if a single outlet is deemed to have sufficient flow to drain the area concerned.

Allow a safety factor of 10% above the published maximum outlet capacity to take account of greater than designed storm intensities.

Check that all outlets are correctly installed before completion or handover.

Check that all pipe connections are secure and that the leaf grilles are fitted.

All rainwater outlets should be inspected twice yearly for blockages and to clean out the outlets and remove any debris or leaf litter as part of the routine maintenance schedule.

Outlet can be used as an emergency overflow. BS 12056 suggests the overflow is set 35mm higher than the outlet it is being used as an emergency overflow for.

Overflows/tell-tale overflows: An appropriate Engineer should consider the requirement for overflows on all roofs. A full capacity overflow should be provided when there is only one outlet on a given roof area.

Safety Data Sheets are designed to provide the necessary information to recipients of substances and mixtures in the EU & UK. This product is classed as an article; therefore, this product does not have a requirement for a Safety Data Sheet.