

Bauder Hot Melt Vertical Outlet DN70 Inc. Clamping Ring

17.02.2026

Product description

A thermally insulated outlet incorporating a one-piece rigid polyurethane foam body that forms the integral sump and spigot designed for use when connecting to conventional gravity drainage systems. The thermal value of the rigid foam body prevents condensation from forming on the underside of the outlet body. The integrated screw down clamping ring ensures security between the waterproofing system and the outlet. It is manufactured with pre-cast studs to receive the fasteners of the clamping ring. This ensures full mechanical sealing between the outlet unit and the Hot Melt Waterproofing and Access / Protection Sheet



Application fields

For use with Bauder Hot Melt system for inverted and cold roofs. The spigot is designed to fit standard 75mm pipework of a conventional gravity drainage systems. (see pipework connectivity information below).

If the outlet is used as part of a Blue Roof it should be installed in conjunction with the BauderBLUE ST-HM adjustable flow restrictor.

Article Number

70DN Vertical Outlet body for Hot Melt, cold, and inverted roofs GB60267080
Bauder Hot Melt Blue Roof Flow Restrictor GB60267310
Bauder Adjustable Hot Melt Blue Roof Flow Restrictor GB60267315
Reinforcement plate for metal decks only GB60266250

Website Link

<https://www.bauder.co.uk/products/compact-vertical-outlet-dn-70>

Characteristic – Hot Melt Vertical Outlet DN 70	Test Method	Unit	Body
Material (body)	DIN EN 1253-2	-	Polyurethane
Size DN (spigot)	-	mm	70 diameter
Outside Diameter (spigot)	-	mm	75 diameter
Outlet Opening	-	mm	146 diameter
Opening/Core borehole (deck)	-	mm	250 diameter
Clamping Ring			
Material	-	-	Aluminium
Size	-	mm	250 diameter
Reinforcement			
Material	-	-	EPDM
Size	-	mm	450 x 450 x 1.5
Shock Pad			
Material	-	-	EPDM
Size	-	mm	250 diameter
Reinforcement Plate (Sold separately)			
Material	DIN EN 1090-4	-	Galvanised steel
Size (external)	-	mm	600 x 600
Internal hole	-	mm	250 diameter
Product testing	EN 1253-2	-	All components comply. Regulated Building Products

Note: When used as part of a Blue Roof System this product requires a BauderBLUE ST-HM adjustable flow restrictor (Hot Melt) to complete the system

Storage guidance

Bauder Hot Melt Compact Vertical Outlet DN 70 should be stored inside. If, however, outside storage cannot be avoided the products should be stacked clear of the ground on a dry and flat level surface. To avoid mechanical damage, it should be protected by a tarpaulin.

Packaging material

Bauder Hot Melt Compact Vertical Outlet DN 70 components are contained within a cardboard box and is stood in a vertical position on a one-way pallet covered with polyethylene shrink wrapping.

Box contains: EPDM Shock Ring (deck seat if required) loose, DN100 Outlet Body loose, 495 x 495mm EPDM Reinforcement loose, Clamping Ring & fixings to secure to main body in polyethylene bag. Installation instructions. Mechanical lifting equipment is required to offload full pallets.

Technical data sheet

Handling/PPE	All persons using this product should be fully aware of the manual handling methods as roofing materials can be heavy and can cause serious injury. When using this product, installers should be provided with, and wear, suitable personal protective equipment. There are no requirements for special PPE when installing Bauder Hot Melt Compact Vertical Outlet DN 70.
Disposal guidance	Waste should be treated as controlled waste. Dispose of waste to licensed waste disposal site in accordance with the requirements of the local Waste Disposal Authority.
Re-use options of product	Please refer to EPD stated below in Certification and environmental information.
Further information/ documents	Current documents such as brochures, installation guides etc can be found by visiting www.bauder.co.uk
Certification and environmental information	ISO 9001:2015 Quality Management Certificate: 12 100/104 14752 TMS ISO 14001:2015 Environmental Management Certificate: 12 100/104 14752 TMS Environmental Product Declaration: EPD-Kiwa-EE-181397-EN
Safety Data Sheet	Safety Data Sheets are designed to provide the necessary information to recipients of substances and mixtures in the EU & UK. This product is classed as an article; therefore, this product does not have a requirement for a Safety Data Sheet.

TECHNICAL DATA

The dimensions of the Hot Melt Compact – Vertical Outlet DN 70 are as shown below:

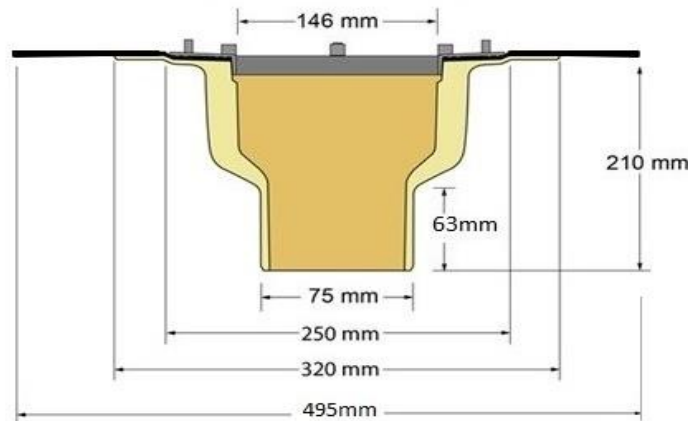

INSTALLATION GUIDANCE

General Installation Instructions

When installing Bauder Insulated outlets, the following should be observed.
The roof outlets should be installed at the low point of the roof falls.
In both instances the outlet body must be mechanically fixed to the deck.
Roof outlets must be freely accessible for maintenance.
Connectivity to below deck drainage pipework to be the responsibility of the plumbing contractor/drainage engineer.

The figures below are based upon the requirements of BS EN 12056: 3: 2000 and performances are given within 1/3 rainwater pipe capacity limits as required by BS EN 12056.

HEAD OF WATER (mm)													
Size	5	10	15	20	25	30	35	40	45	50	55	60	65
70	0.7	1.7	2.7	3.8	4.8	6.0	7.1	8.3	9.4	10.8	12.2	13.5	14.8

Flow rates for the Bauder Hot Melt Compact Vertical Outlet DN 70 when used with the BauderBLUE ST-HM adjustable flow restrictor (sold separately) are project specific. Please contact Bauder Technical for further information.

When designing a rainwater scheme, the following considerations should apply:

Always make provision for an additional back-up outlet to ensure that the roof will continue to drain in the event of a blockage, even if a single outlet is deemed to have sufficient flow to drain the area concerned.

Allow a safety factor of 10% above the published maximum outlet capacity to take account of greater than designed storm intensities.

Check that all outlets are correctly installed before completion or handover.

Technical data sheet

Check that all pipe connections are secure and that the leaf grilles are fitted.

All rainwater outlets should be inspected twice yearly for blockages and to clean out the outlets and remove any debris or leaf litter as part of the routine maintenance schedule.

PROFILED METAL DECKS

With profiled metal decks, the hole penetration is to be reinforced by a galvanised steel strengthening sheet (available from Bauder Ltd.)

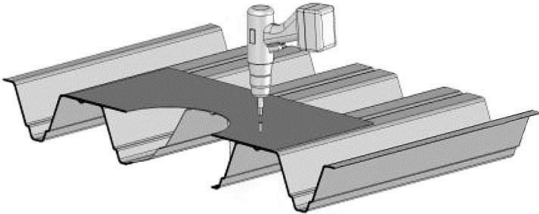

In the case of profiled galvanised steel decking, the edges of the cut hole to be treated to prevent future corrosion.

CONCRETE DECKS

With cast in-situ concrete decks, the roof outlet hole for should be pre-cast into the deck using formwork. The outlet is an integral component of the Bauder waterproofing system, and this precaution is important to prevent damage to the outlet and the waterproof connecting flange prior to installation.

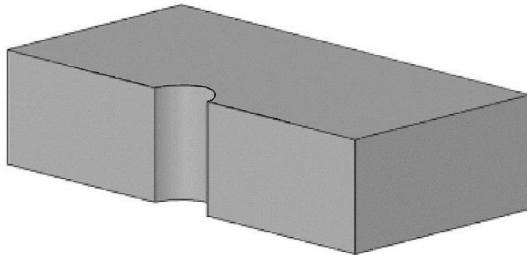

For concrete decks, the roof outlet hole (Ø 250 mm) should be pre-cast in-situ so the outlet can be installed by the roofing contractor when the waterproofing system is installed.

Concrete deck Installation Instructions

1. Core hole through concrete deck 250mm or cast in-situ.
2. Place smaller diameter shock pad EPDM gasket on to deck surface if installation is via a pre cored hole.
3. Install outlet into hole sitting on top of shock pad EPDM gasket.
4. Mechanically fasten the outlet into substrate using the three pre-drilled holes in the polyurethane outlet flange.
5. Install the first layer of Bakor 790-11 Hot Melt Waterproofing on to the first 35mm of the polyurethane outlet flange.
Note If the first coat of Hot melt is taken further than this into the depression on the flange, it is very difficult to sit the screw flange correctly
6. Install the large 495 x 495mm EPDM Reinforcement into the hot first layer of Bakor 790-11 Hot Melt Waterproofing
7. Install the second coat of Bakor 790-11 Hot Melt Waterproofing, fully covering the EPDM reinforcement up to the edge of the outlet opening.
8. Install the Bauder Access/Protection Sheet over the hot Bakor 790-11 Hot Melt Waterproofing second coat and trim to ensure the outlet hole is clear and free from waterproofing material. The Bakor 790-11 Hot Melt Waterproofing must encapsulate the whole of the 495 x 495mm EPDM Reinforcement
9. Place the clamping ring into position ensuring it provides a physical clamp between the Bauder Protection Sheet and outlet body. Tighten the countersunk head screws supplied with a screwdriver.

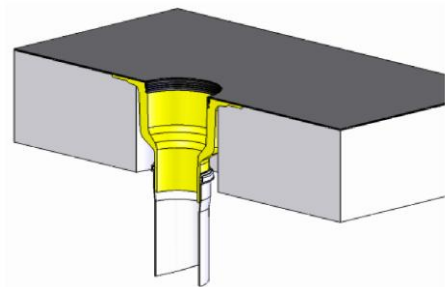

Technical data sheet

CONNECTION TO PIPEWORK

Hot Melt Compact – Insulated Vertical Outlets are suitable for connection to:

- 70 mm uPVC “O” ring socketed soil grade pipe to BS 4514: 1983
- Socketed and socket-less cast-iron pipework to BS 416:1973 and EN 887. Socketed pipework will require cold caulking or PVC to cast iron adaptors. Socket less pipework can be connected using an appropriate seamless mechanical coupling
- HDPE pipework with appropriate seamless mechanical coupling

The following considerations should apply:

Always make provision for additional back-up outlet and/or Bauder Overflow/Tell Tails to ensure that the roof will continue to drain in the event of a blockage, even if a single outlet is deemed to have sufficient flow to drain the area concerned.

Allow a safety factor of 10% above the published maximum outlet capacity to take account of greater than designed storm intensities.

Check that all outlets are correctly installed before completion or handover.

Check that all pipe connections are secure and that the leaf grilles are fitted.

All rainwater outlets should be inspected twice yearly for blockages and to clean out the outlets and remove any debris or leaf litter as part of the routine maintenance schedule.

GENERAL BLUE ROOF INFORMATION

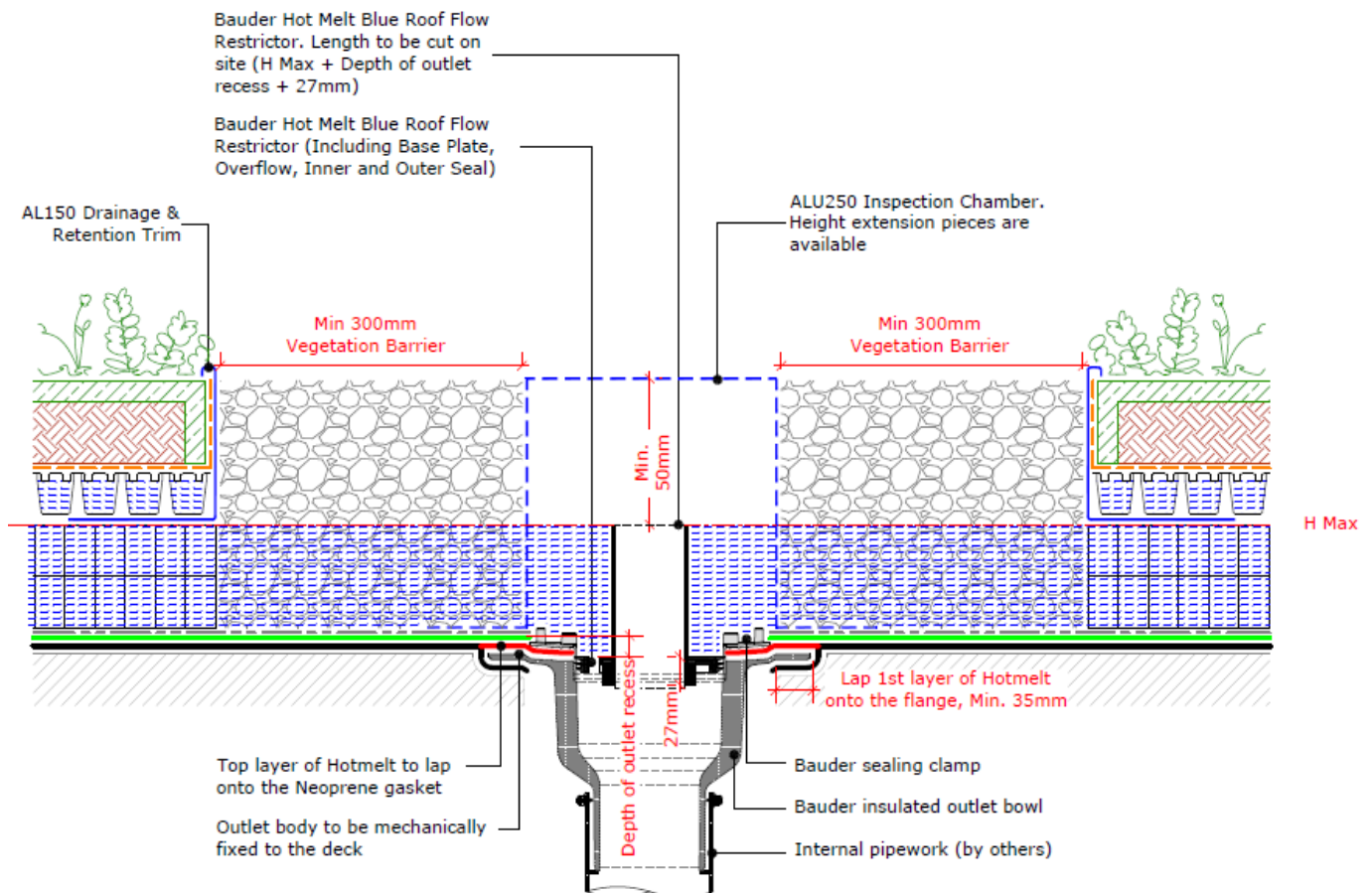

BLUE ROOF SURFACE FINISHES

Blue Roofs should have a surface finish above the water attenuation layers, this surface finish can be constructed from any suitable permeable surface, to provide visual masking, protection of the system, filtration of airborne debris to prevent blockages and ballasting preventing wind uplift and floatation of the components. An impermeable surface can be used but adequate measures should be taken to ensure the water can filter into the Blue Roof attenuation void.

BLUE ROOF DESIGN GUIDANCE

- A Blue Roof should not be considered as a water storage solution.
- No British or European standard covers this type of application at the present time.
- The Blue Roof must be designed to attenuate the predicted rainfall volume required to prevent ponding or flooding on the roof surface. The surfacing should drain by direct permeability or drainage channels linking into the Blue Roof system.
- Emergency drainage must be provided within the primary outlet or by a secondary method of drainage to facilitate the removal of excess rainfall if the designed capacity is exceeded, this should be placed at the top of the water attenuation layer.
- The Blue Roof, void forming components, thermal insulation and waterproofing must have the correct structural capacity to resist the permanent (dead) load of the required finishes and any temporary (live) loading produced by maintenance/emergency vehicles or other elements. The components should be designed to accommodate the full capacity of the predicted storm water for a 24-hour period.
- All components must have chemical resistance to all potential hazardous material e.g. Fertilisers, petrochemicals and water bound pollutants carried in by rainfall typically from 4-9PH.
- An electronic or suitable integrity test should take place, by an independent and competent person, on the completed waterproofing prior to the installation of any Blue Roof void forming or landscaping components. The satisfactory waterproofing integrity certification must be retained.
- See Bauder's Blue Roof Design Considerations for more information.

BLUE ROOF MAINTENANCE GUIDANCE

When maintaining a blue roof, the following considerations should apply:

- Regularly clear all debris from the roof surface, rainwater outlets, chutes, gutters etc. Debris must be removed from the roof and not simply flushed down rainwater pipes.
- Annually inspect the waterproofing system visible at all upstands, to ensure it is firmly adhered to the detail that it is waterproofing.
- Cut back tree limbs that overhang the roof to give a one metre clearance outside the roof edge. This will significantly reduce blockage of drainage ways due to fallen leaves.
- Ensure that all rainwater pipes are free from blockages and that water flows freely through them.
- For full details see Bauder's Blue Roof Maintenance Guide.

Safety Data Sheets are designed to provide the necessary information to recipients of substances and mixtures in the EU & UK. This product is classed as an article; therefore, this product does not have a requirement for a Safety Data Sheet.